



LIGHTING CREATOR

ELECTRIC VEHICLE CHARGER STAND

Our P1 Electric Vehicle Charger Stand is designed to accommodate the vast majority of Level 2 electric chargers on the market.

This pedestal features an optional LED lighting unit, which is automatically controlled by a photocell sensor.

NOTE: Please refer to your specific charger's installation manual to complete installation.

L-BOLTS RECOMMENDED INSTALLATION

1. Place bolts in wet cement.
For added strength, add rebar over "L" bolts.
2. After cement has cured, place the pedestal.
3. Install washers and nuts.

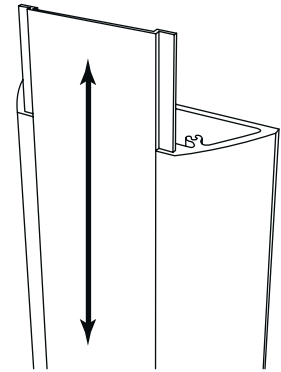
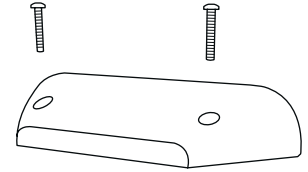
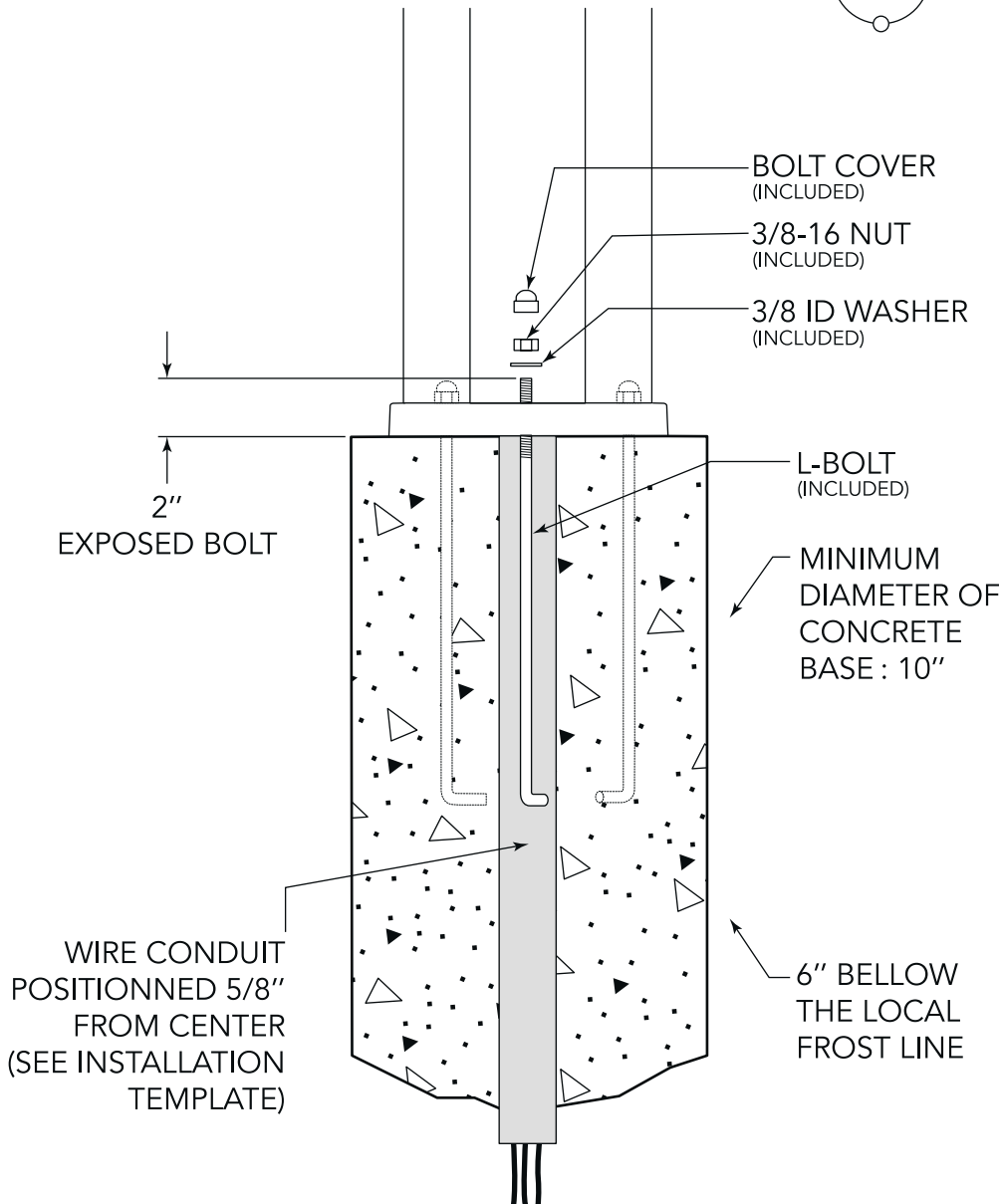

REAR PANEL

1. Remove the 2 screws on the top cover in order to slide out the rear panel.

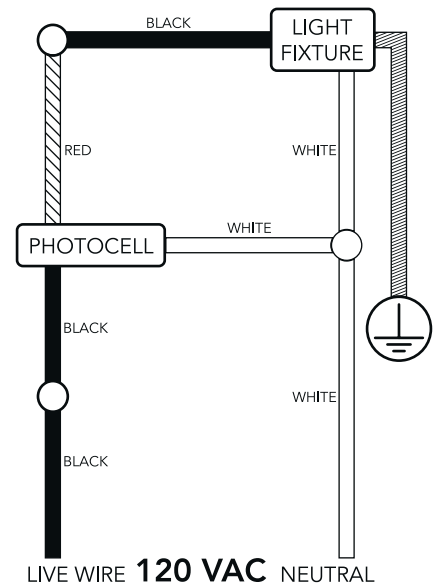

WARNING:

The installation of all electrical components *must be done by a licensed electrician.*



LIGHTING CREATOR

ELECTRIC VEHICLE CHARGER STAND P1

INSTALLATION TEMPLATE FOR 6" DIAMETER BOLT CIRCLE

HARDWARE SUPPLIED:

- L bolts
- 3/8 ID washers
- 3/8-16 nuts
- Bolt covers

NOTE: Please rely on the written dimensions shown on the drawing, since, when printed, this file may not be at a scale 1:1.

↑
CHARGER WILL BE FACING THIS DIRECTION

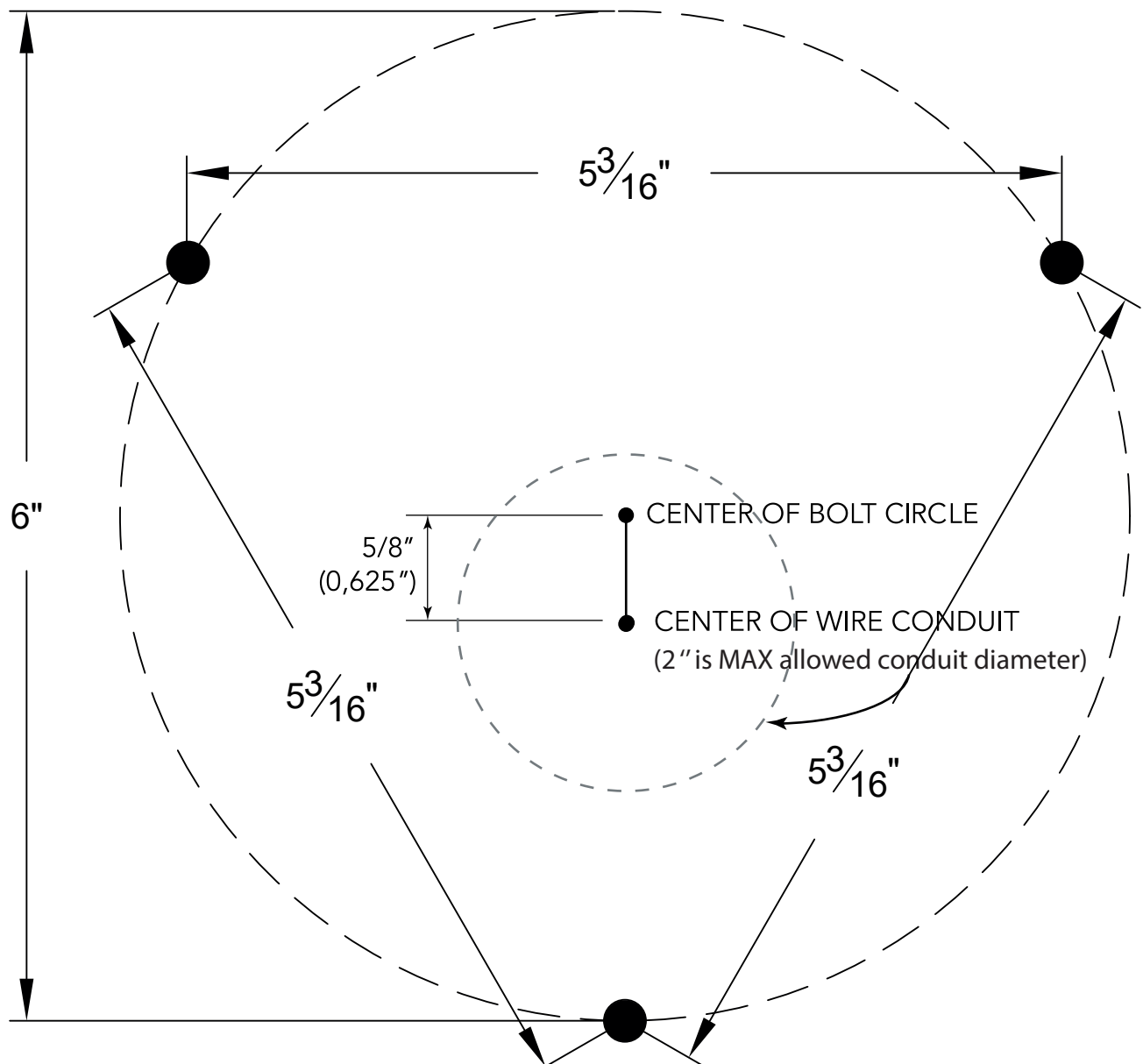

IMPORTANT:

Make sure to offset center of conduit by 5/8" (0,625") from center of bolting circle.